

## Operating Instructions

### HV 25-1 | HV 25-2

Circular Knife Grinding Attachment



# Operating Instructions

---

## HV 25-1 | HV 25-2 Circular Knife Grinding Attachment

### Manufacturer

KNECHT Maschinenbau GmbH  
Witschwender Straße 26  
88368 Bergatreute  
Germany

Phone +49-7527-928-0  
Fax +49-7527-928-32

mail@knecht.eu  
www.knecht.eu

### Documents for machine operator

Operating Instructions

### Date of issue of the operating instructions

May 26, 2026

### Copyright

These operating instructions as well as the operating documents remain the copyright property of KNECHT Maschinenbau GmbH. They are supplied only to customers and operators of our products and belong to the machine.

Without our express permission, these documents may neither be duplicated nor made accessible to third parties, in particular competitor companies.

# Table of Contents

---

<b>1.</b>	<b>Important notes</b>	<b>7</b>
<b>1.1</b>	<b>Preface to the operating instructions</b>	<b>7</b>
<b>1.2</b>	<b>Warnings and symbols in the operating instructions</b>	<b>7</b>
<b>1.3</b>	<b>Figure and position numbers in the operating instructions</b>	<b>8</b>
<b>2.</b>	<b>Safety</b>	<b>9</b>
<b>2.1</b>	<b>Basic safety instructions</b>	<b>9</b>
2.1.1	Observe notes in the operating instructions	9
2.1.2	Obligation on the part of the operator	9
2.1.3	Obligation on the part of the personnel	9
2.1.4	Hazards involved in handling the circular knife grinding attachment	9
2.1.5	Malfunctions	10
<b>2.2</b>	<b>Intended use</b>	<b>10</b>
<b>2.3</b>	<b>Warranty and liability</b>	<b>10</b>
<b>2.4</b>	<b>Safety regulations</b>	<b>11</b>
2.4.1	Organizational measures	11
2.4.2	Protective equipment	11
2.4.3	Informal safety measures	11
2.4.4	Selection and qualification of personnel	12
2.4.5	Machine control system	12
2.4.6	Safety measures in normal operation	12
2.4.7	Hazards due to electrical power sources	12
2.4.8	Particular hazard areas	12
2.4.9	Servicing (maintenance, repair) and fault rectification	13
2.4.10	Structural alterations to the circular knife grinding attachment	13
2.4.11	Cleaning the circular knife grinding attachment	13
2.4.12	Lubricants/oils and greases	13
2.4.13	Relocation of the grinding machine with circular knife grinding attachment	13
<b>3.</b>	<b>Description</b>	<b>15</b>
<b>3.1</b>	<b>Intended use</b>	<b>15</b>
<b>3.2</b>	<b>Technical specifications</b>	<b>15</b>
3.2.1	HV25-1 Circular Knife Grinding Attachment	15
3.2.2	HV25-2 Circular Knife Grinding Attachment	16
<b>3.3</b>	<b>Functional description</b>	<b>16</b>
<b>3.4</b>	<b>Description of the assemblies</b>	<b>17</b>
3.4.1	HV25-1 Circular Knife Grinding Attachment for circular knives d. 80–250 mm	17
3.4.2	HV25-2 Circular Knife Grinding Attachment for circular knives d. 250–470 mm	18
<b>4.</b>	<b>Transport</b>	<b>19</b>
<b>4.1</b>	<b>Transport aids</b>	<b>19</b>

# Table of Contents

---

<b>4.2</b>	<b>Transport damage</b>	<b>19</b>
<b>4.3</b>	<b>Transport to another installation site</b>	<b>19</b>
<b>5.</b>	<b>Installation</b>	<b>20</b>
<b>5.1</b>	<b>Selection of qualified personnel</b>	<b>20</b>
<b>5.2</b>	<b>Installation site</b>	<b>20</b>
<b>5.3</b>	<b>Settings</b>	<b>20</b>
<b>5.4</b>	<b>Initial start-up of the circular knife grinding attachment</b>	<b>20</b>
<b>6.</b>	<b>Commissioning</b>	<b>21</b>
<b>6.1</b>	<b>Mounting the HV25-1   HV25-2 Circular Knife Grinding Attachment</b>	<b>21</b>
<b>7.</b>	<b>Operation</b>	<b>24</b>
<b>7.1</b>	<b>Grinding circular knives d. 80–250 mm on the grinding wheel</b>	<b>24</b>
7.1.1	Clamping the circular knife	24
7.1.2	Positioning the circular knife on the grinding wheel	26
7.1.3	Swiveling the circular knife grinding attachment	26
7.1.4	Setting the grinding angle	27
7.1.5	Grinding the circular knife	28
7.1.6	Deburring the circular knife	29
<b>7.2</b>	<b>Grinding circular knives d. 250–470 mm on the grinding wheel</b>	<b>30</b>
7.2.1	Clamping the circular knife	30
7.2.2	Positioning the circular knife on the grinding wheel	32
7.2.3	Setting the grinding angle	32
7.2.4	Grinding the circular knife	34
7.2.5	Deburring the circular knife	35
<b>8.</b>	<b>Care and maintenance</b>	<b>36</b>
<b>8.1</b>	<b>Cleaning</b>	<b>36</b>
8.1.1	Cleaning agent and lubricant table	36
<b>8.2</b>	<b>Maintenance plan (one-shift operation)</b>	<b>36</b>
<b>9.</b>	<b>Disassembly and disposal</b>	<b>37</b>
<b>9.1</b>	<b>Disassembly</b>	<b>37</b>
<b>9.2</b>	<b>Disposal</b>	<b>37</b>

# Table of Contents

---

<b>10.</b>	<b>Service, spare parts and accessories</b>	<b>38</b>
<b>10.1</b>	<b>Postal address</b>	<b>38</b>
<b>10.2</b>	<b>Service</b>	<b>38</b>
<b>10.3</b>	<b>Wear and spare parts</b>	<b>38</b>
<b>10.4</b>	<b>Accessories</b>	<b>39</b>
10.4.1	Abrasives used, etc.	39
<b>11.</b>	<b>Appendix</b>	<b>40</b>
<b>11.1</b>	<b>EU Declaration of Conformity</b>	<b>40</b>

# 1. Important notes

---

## 1.1 Preface to the operating instructions

These operating instructions are intended to make it easy to learn how to use the circular knife grinding attachment and to properly utilize its features.

These operating instructions contain important notes on how to operate the circular knife grinding attachment safely, properly, and efficiently. Your attention helps to avoid hazards, reduce repair costs and downtimes, and to increase the reliability and service life of the circular knife grinding attachment.

The operating instructions must be permanently available at the place of use of the circular knife grinding attachment.

The operating instructions must be read and applied by every person tasked with working with the circular knife grinding attachment, e.g.:

- transport, installation, commissioning
- operation, including error rectification during operation, as well as
- servicing (maintenance, repair).

Recognized technical standards for safe and professional work must be observed in addition to these operating instructions and the binding accident prevention regulations applicable in the country of use and at the place of use.

## 1.2 Warnings and symbols in the operating instructions

The operating instructions use the following symbols/designations that must be followed:



The hazard triangle with the signal word "CAUTION" serves as a work safety notice for all work for which there is a risk of personal injury or death.

In these cases, work should be done with special attention and care.



"ATTENTION" is written in places where special attention must be paid to prevent damage or destruction of the grinding machine or its surroundings.



"NOTICE" refers to user tips and especially useful information.

# 1. Important notes

---

## 1.3 Figure and position numbers in the operating instructions

If the text makes a reference to a machine component depicted in a figure, the figure and position number is given in brackets.

Example: (7-17/1) means picture number 7-17, position 1.

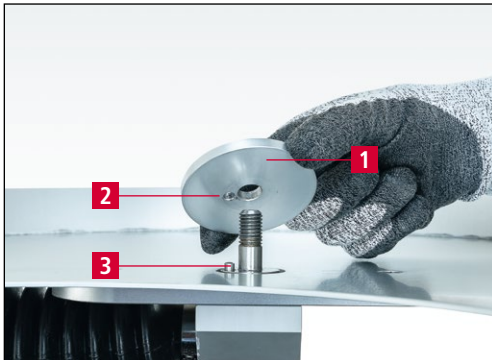

*Fit the mounting flange d.70 mm (7-17/1) with the hole (7-17/2) facing downwards onto the locating bolt (7-17/3).*

**Figure 7-17** Holding flange d. 70

## 2. Safety

---

### 2.1 Basic safety instructions

#### 2.1.1 Observe notes in the operating instructions

The basic prerequisite for safe handling and uninterrupted operation of this circular knife grinding attachment is knowledge of the basic safety instructions and regulations.

- These operating instructions contain important notes on how to operate the circular knife grinding attachment safely.
- All persons carrying out work on the circular knife grinding attachment must follow these operating instructions, in particular the safety notices.
- In addition, the rules and regulations regarding accident prevention at the place of use are to be observed.

#### 2.1.2 Obligation on the part of the operator

The operator is obliged to allow only those persons to work on the circular knife grinding attachment, who

- are familiar with the occupational safety and accident prevention regulations and have received instruction in handling the circular knife grinding attachment,
- have read and understood the operating instructions, in particular the section entitled "Safety" and the warning notes, and have provided signed confirmation of this.

The safety-awareness of the personnel at work will be monitored at regular intervals.

#### 2.1.3 Obligation on the part of the personnel

All personnel working on the circular knife grinding attachment shall be obliged, before starting work, to

- observe basic occupational safety and accident prevention regulations,
- read the operating instructions, particularly the section entitled "Safety" and the warning notes, and provide signed confirmation that they have understood them.

#### 2.1.4 Hazards involved in handling the circular knife grinding attachment

The circular knife grinding attachment has been built to the latest technological standards and the recognized rules of technical safety. Nevertheless, its use may result in danger to life and limb of the user or third parties, or damage to the circular knife grinding attachment or other property.

## 2. Safety

---

The circular knife grinding attachment may be used only

- for its intended purpose
- in a safe and secure condition.

Malfunctions that may impair safety are to be eliminated immediately.

### 2.1.5 Malfunctions

If safety-relevant malfunctions occur with the circular knife grinding attachment, or if the processing behavior indicates that such malfunctions may have occurred, the circular knife grinding attachment must be stopped immediately and until such time as the malfunction has been found and eliminated.

Allow only authorized trained personnel to eliminate the malfunctions.

## 2.2 Intended use

The circular knife grinding attachment is only for grinding circular knives from 80-250 mm (HV25-1) and 250-470 mm (HV25-2). It is meant to be installed onto KNECHT grinding machines of the S20 series only.

All circular knives must be clamped onto corresponding holding fixtures. First, check whether the holding fixture matches the knife to be ground. The knife can only be ground if this is the case.

Any other use is considered to be improper. KNECHT Maschinenbau GmbH is not liable for any damage arising from this. The risk is borne solely by the user.

Intended use also includes observing all instructions in the operating manual.

### **ATTENTION**

**Improper use of the circular knife grinding attachment exists, for example if:**

- **it is installed onto grinding machines other than the KNECHT S 20 series,**
- **the circular knife has been clamped incorrectly,**
- **fixtures are not properly attached.**

## 2.3 Warranty and liability

Warranty and liability claims in case of personal injury or property damage are excluded if such damage is attributable to one or more of the following causes:

## 2. Safety

---

- improper use of the circular knife grinding attachment,
- improper transport, commissioning, operation, and maintenance of the circular knife grinding attachment,
- operating the circular knife grinding attachment with defective safety devices, or using improperly attached or malfunctioning safety and protective equipment,
- failure to observe the instructions with regard to transportation, commissioning, operation, maintenance and repair of the circular knife grinding attachment,
- unauthorized structural alterations to the circular knife grinding attachment,
- failure to monitor machine parts that are subject to wear, and
- use of unapproved replacement and wear parts.

Use only original replacement and wear parts. If externally purchased parts are used, it is not guaranteed that they have been designed and manufactured to meet the requirements in terms of stress and safety.

### 2.4 Safety regulations

#### 2.4.1 Organizational measures

Inspect all available safety devices regularly.

Observe prescribed intervals for recurring maintenance work or as specified in the operating instructions!

#### 2.4.2 Protective equipment

Before commissioning and any operation of the circular knife grinding attachment, always ensure that all protective equipment is properly mounted and in functional condition.

Protective equipment may be removed only after the circular knife grinding attachment has stopped and has been secured against accidental restart.

After any technical work, for example such as maintenance, the operator must install the protective equipment according to the regulations.

#### 2.4.3 Informal safety measures

The operating instructions must be permanently available at the place of use of the circular knife grinding attachment. In addition to the operating instructions, the generally applicable as well as locally relevant accident prevention regulations must also be made available and observed.

All safety alert symbols and hazard warnings on the circular knife grinding attachment must be complete and clearly legible.

## 2. Safety

---

### 2.4.4 Selection and qualification of personnel

Only trained and instructed personnel may work on the circular knife grinding attachment. Observe the legally permitted minimum age!

The responsibilities of personnel with respect to commissioning, operation, maintenance, and repair must be clearly specified.

Personnel still undergoing training or instruction may only work on the circular knife grinding attachment under the permanent supervision of an experienced person!

### 2.4.5 Machine control system

Only trained and instructed personnel are permitted to switch on and operate the machine.

### 2.4.6 Safety measures in normal operation

Do not operate the machine in any unsafe manner. Only operate the circular knife grinding attachment if all safety devices are installed and fully functional.

At least once per shift (or per day), check the circular knife grinding attachment for externally visible damage and proper functioning of the safety devices.

Immediately report any changes present (including those of the operating behavior) to the responsible office or person. If necessary, immediately shut down the circular knife grinding attachment and secure it against restart.

Before you switch on the grinding machine, ensure that no one can be injured by the start-up of the machine.

In the event of a malfunction, immediately stop the grinding machine and secure it against restart. Rectify malfunctions immediately.

### 2.4.7 Hazards due to electrical power sources

Work on electrical systems or operating materials may only be performed by a qualified electrician, in accordance with electrical regulations.

Defects, such as damaged cables, cable connections, etc. must be immediately rectified by an authorized specialist.

### 2.4.8 Particular hazard areas

In the area of the grinding wheel, wet-grinding belt and finned brushes, there is a hazard of pinching and being drawn in, e.g. clothing, fingers and hair. Wear suitable personal protective equipment.

## 2. Safety

---

### 2.4.9 Servicing (maintenance, repair) and fault rectification

Maintenance work is to be carried out on schedule by trained personnel. Inform operating personnel before beginning repair work. Designate a supervisor responsible for this.

For all service work, the grinding machine is to be disconnected from the current supply and secured against accidental restart.

Remove power plug. Secure repair area as necessary.

After completing maintenance work and rectifying any faults, install all safety devices and verify that they are fully functional.

### 2.4.10 Structural alterations to the circular knife grinding attachment

Do not make any changes, additions or conversions to the circular knife grinding attachment without the approval of the manufacturer. This also applies for installation and configuration of the safety devices.

Any conversion work requires the written permission from KNECHT Maschinenbau GmbH.

Immediately replace machine parts that are not in perfect condition.

Use only original replacement and wear parts. If externally purchased parts are used, it is not guaranteed that they have been designed and manufactured to meet the requirements in terms of stress and safety.

### 2.4.11 Cleaning the circular knife grinding attachment

Properly handle any cleaning agents and materials used and dispose of them in an environmentally-friendly manner.

Dispose of the wear parts and replacement parts in a safe and environment friendly manner.

### 2.4.12 Lubricants/oils and greases

When using oils and greases, follow the safety regulations applicable to the product. Comply with the special regulations for the food areas.

### 2.4.13 Relocation of the grinding machine with circular knife grinding attachment

Disconnect the grinding machine with the circular knife grinding attachment from any external power supply, even in the event of a minor change of location. Before restarting the grinding machine, connect it properly to the power supply.

For loading work, use only lifting equipment and load-bearing devices with sufficient lifting capacity. Appoint a qualified instructor for the lifting operation.

## 2. Safety

---

No persons other than those designated for this work may be present in the loading and installation area.

Only use a suitable transport vehicle with sufficient load-bearing capacity. Secure the load reliably. See also Chapter 4 of the Operating instructions for the S20 Universal Wet-Sharpener Machine.

When restarting the machine, proceed only in accordance with the operating instructions.

# 3. Description

---

## 3.1 Intended use

The HV25-1 and HV25-2 Circular Knife Grinding Attachments are used to grind circular knives. The devices are used on the KNECHT grinding machines of the S20 model series.

## 3.2 Technical specifications

### 3.2.1 HV25-1 Circular Knife Grinding Attachment

Height \_\_\_\_\_ approx. 250 mm

Width \_\_\_\_\_ approx. 270 mm

Depth \_\_\_\_\_ approx. 340 mm

Weight \_\_\_\_\_ approx. 2,5 kg

Grinding range \_\_\_\_\_ circular knives d. 80–250 mm

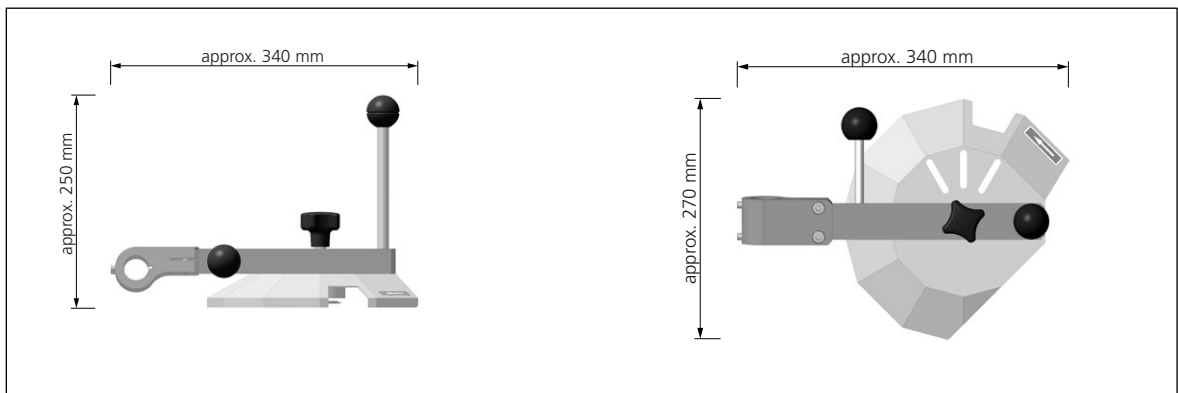

**Figure 3-1** Dimensions in mm (HV25-1 side view / top view)

# 3. Description

---

## 3.2.2 HV25-2 Circular Knife Grinding Attachment

Height \_\_\_\_\_ approx. 370 mm

Width \_\_\_\_\_ approx. 550 mm

Depth \_\_\_\_\_ approx. 500 mm

Weight \_\_\_\_\_ approx. 6 kg

Grinding range \_\_\_\_\_ circular knives d. 250–470 mm

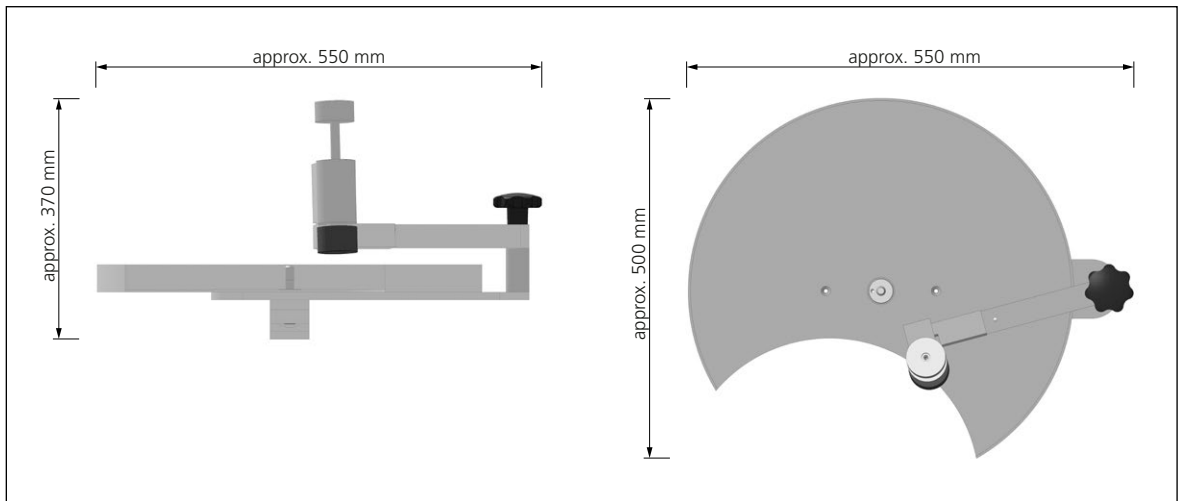

**Figure 3-2** Dimensions in mm (HV25-2 front view / top view)

## 3.3 Functional description

For grinding circular knives (d. 80–250 mm), the HV25-1 Circular Knife Grinding Attachment is mounted on the S20 grinding machine.

For grinding circular knives (d. 250–470 mm), the HV25-2 Circular Knife Grinding Attachment is mounted on the S20 grinding machine.

The circular knife grinding attachments enable angle-precise grinding with simple operation and very little effort. Circular knives with chipping on the cutting edge can be easily repaired here.

# 3. Description

## 3.4 Description of the assemblies

### 3.4.1 HV25-1 Circular Knife Grinding Attachment for circular knives d. 80–250 mm

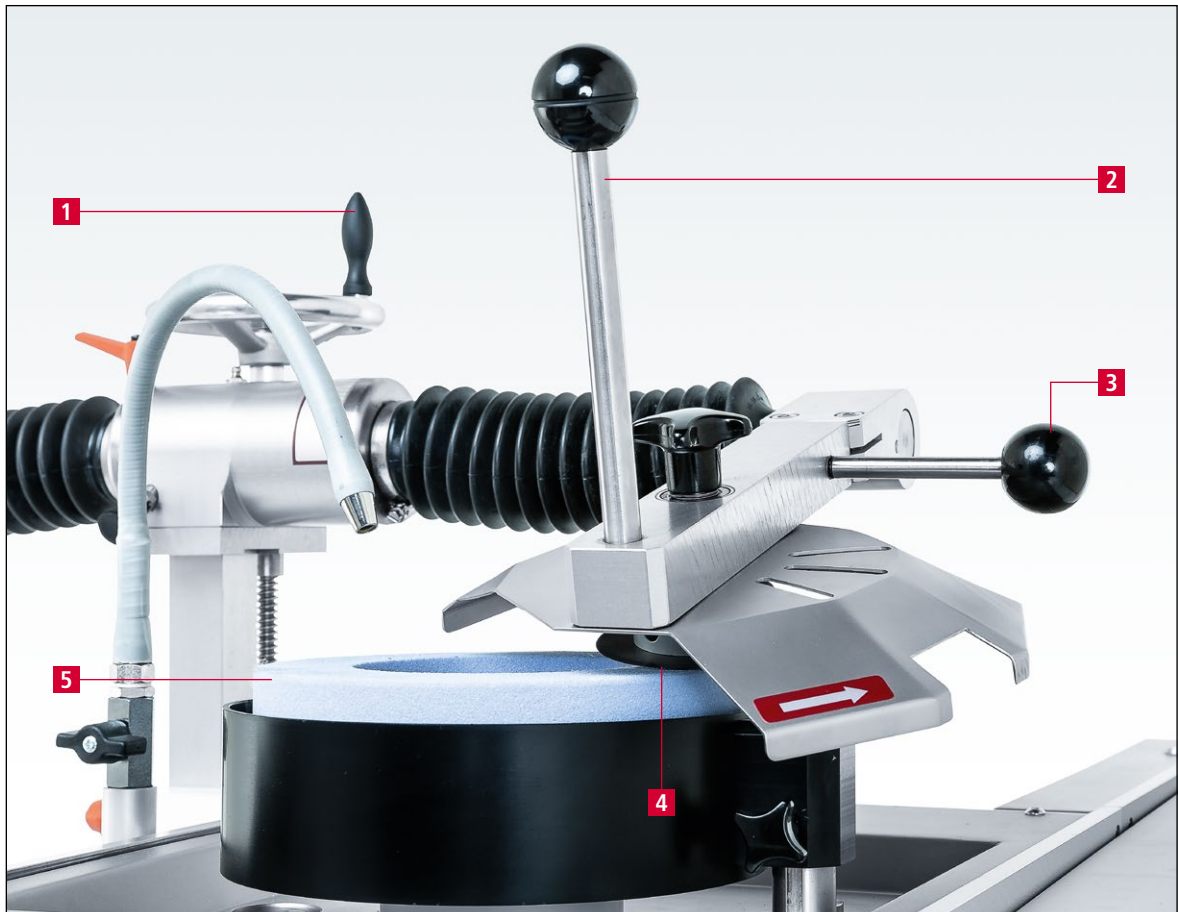

**Figure 3-3** HV25-1 Circular Knife Grinding Attachment

- 1 Hand wheel for angle adjustment
- 2 Grinding lever
- 3 Locking pin
- 4 Circular knife d. 90 mm
- 5 Grinding wheel with guard

## 3. Description

---

### 3.4.2 HV25-2 Circular Knife Grinding Attachment for circular knives d. 250–470 mm

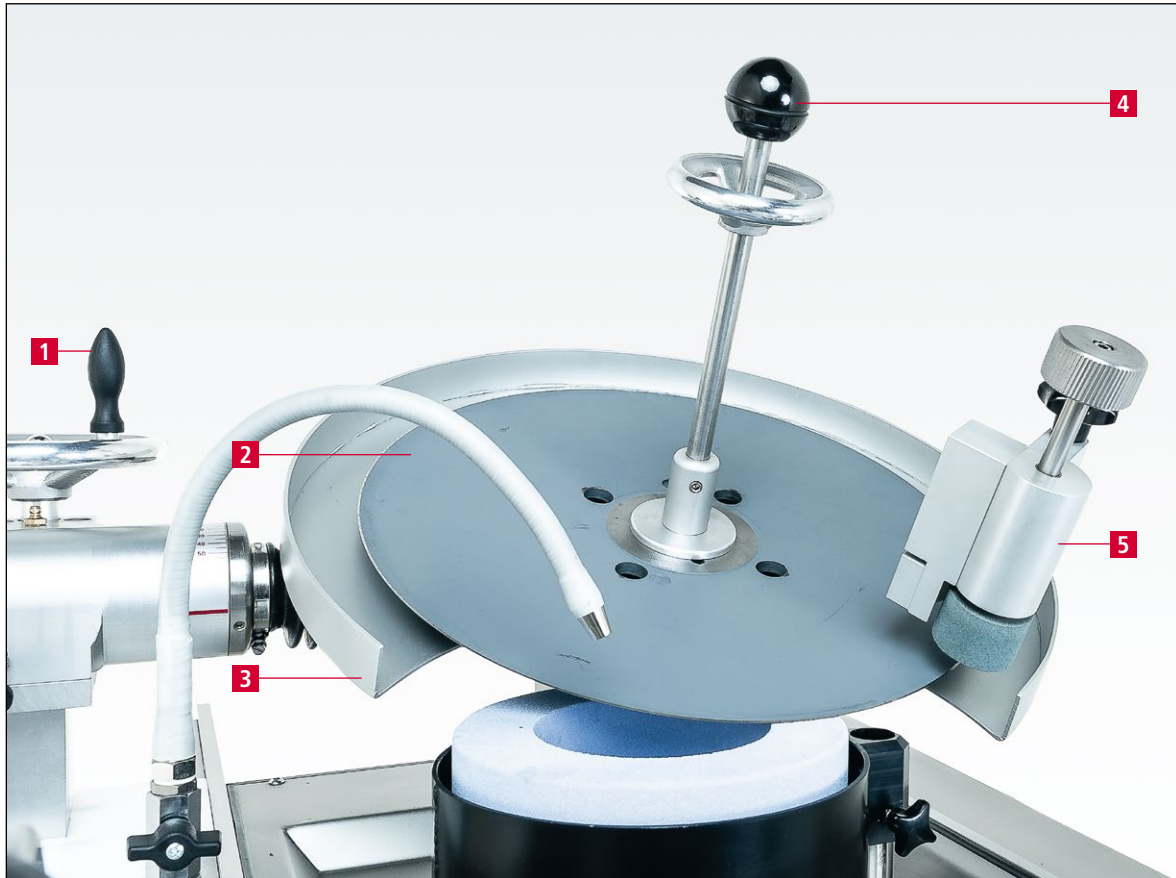

**Figure 3-4** HV25-2 Circular Knife Grinding Attachment

- 1 Hand wheel for angle adjustment
- 2 Circular knife d. 430 mm
- 3 Knife guard
- 4 Grinding lever SH 104
- 5 Deburring device

## 4. Transport

---



When transporting, observe the local applicable safety and accident prevention regulations.

### 4.1 Transport aids

For transporting the circular knife grinding attachment, only use adequately dimensioned transport aids.

### 4.2 Transport damage

If damage is detected during acceptance of the delivery, immediately inform KNECHT Maschinenbau GmbH and the forwarding agent. If necessary, an independent expert must be called in immediately.

Remove packaging and fastening straps. Dispose of packaging in an environmentally-friendly manner.

### 4.3 Transport to another installation site

For transport to another installation site, ensure that the space requirements are fulfilled (see Operating instructions S20 | S20 B, Chapter 3.2.2).

The circular knife grinding attachment must be secured properly during transport.

# 5. Installation

---

## 5.1 Selection of qualified personnel



We recommend having installation work on the circular knife grinding attachment carried out by trained KNECHT personnel.

We are not liable for any damage resulting from improper installation.

## 5.2 Installation site

When determining the installation site, bear in mind the space required for installation as well as maintenance and repair work on the circular knife grinding attachment (see Operating instructions S20 | S20 B, Chapter 3.2.2).

## 5.3 Settings

KNECHT Maschinenbau GmbH will configure the various components before delivery.

### ATTENTION

Unauthorized alterations to the preset values are not permitted and can damage the circular knife grinding attachment and grinding machine.

## 5.4 Initial start-up of the circular knife grinding attachment

Completely install and inspect the protective equipment before commissioning.

The circular knife grinding attachment is only suitable for attachment to KNECHT grinding machines of the S20 model series.



Have all protective equipment checked for proper functioning by authorized trained personnel before commissioning the machine.

## 6. Commissioning

---



All work may only be performed by authorized specialist personnel.

Observe the locally applicable safety and accident prevention regulations.

There is a risk that hands, hair, and clothing may be pulled in while the grinding machine is switched on.

Serious injury may result. Wear personal protective equipment.

### 6.1 Mounting the HV25-1 | HV25-2 Circular Knife Grinding Attachment

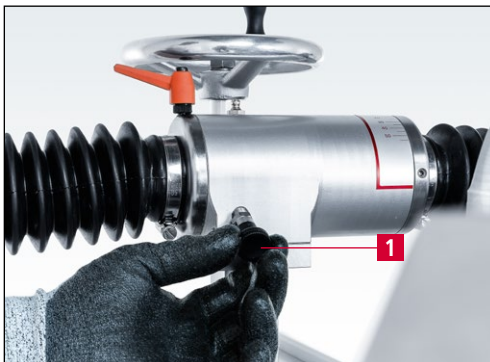

Figure 6-1 Engaging the locking bolt

Engage the locking bolt (6-1/1).

The grinding arm is now locked against swiveling.



Figure 6-2 Loosening the set screws

Using an AF4 mm hexagon screwdriver, loosen the two M8 set screws (6-2/1) **counterclockwise**.

## 6. Commissioning

---



**Figure 6-3** Removing the mounting head

Pull the standard mounting head (6-3/1) off the side of the grinding arm.

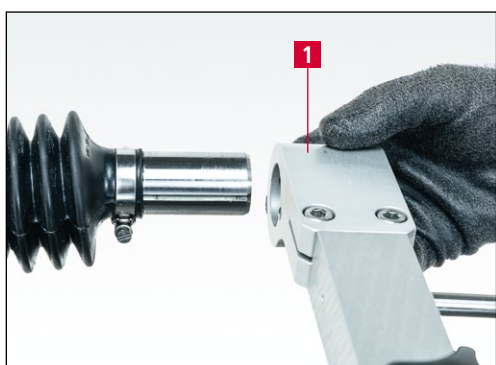

**Figure 6-4** Mounting the circular knife grinding attachment

Push the HV25-1 | HV25-2 Circular Knife Grinding Attachment (6-4/1) completely onto the grinding arm from the right.

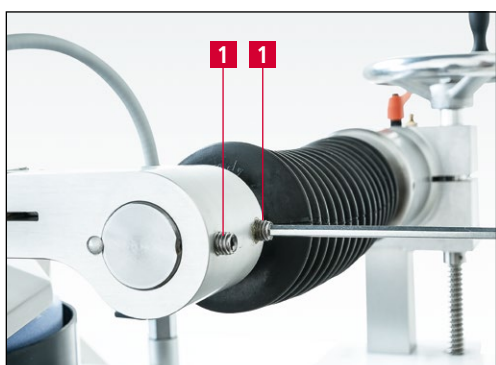

**Figure 6-5** Tightening the circular knife grinding attachment

Using an AF4 mm hexagon screwdriver, tighten the two M8 set screws (6-5/1) in a **clockwise direction**.

The circular knife grinding attachment is now firmly connected to the grinding arm.

## 6. Commissioning

---

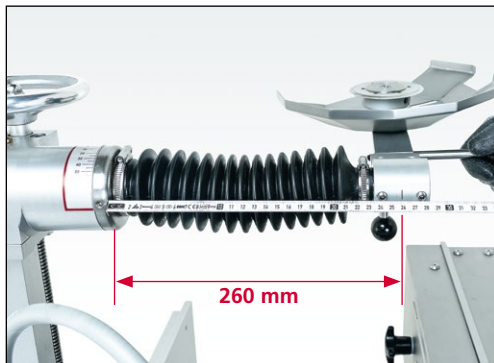

**Figure 6-6** Positioning the circular knife grinding attachment to the grinding wheel

Move the grinding arm so that the center of the circular knife grinding attachment is positioned 260 mm from the angle display.

A mark on the mounting head of the circular knife grinding attachment indicates the center. Use a measuring tape.

The circular knife holder is now positioned centrally to the right grinding surface of the cup grinding wheel.

# 7. Operation

---

## 7.1 Grinding circular knives d. 80–250 mm on the grinding wheel



**Figure 7-1** HV25-1 Circular knife grinding attachment

Mount the HV25-1 Circular Knife Grinding Attachment according to the instructions (see Chapter 6.1).

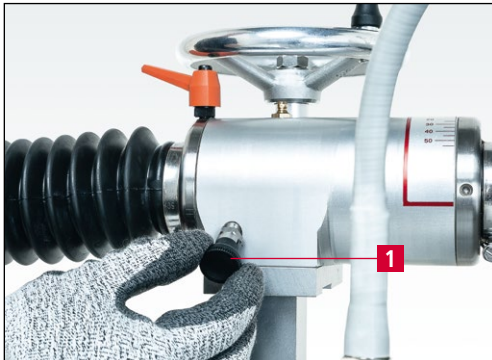
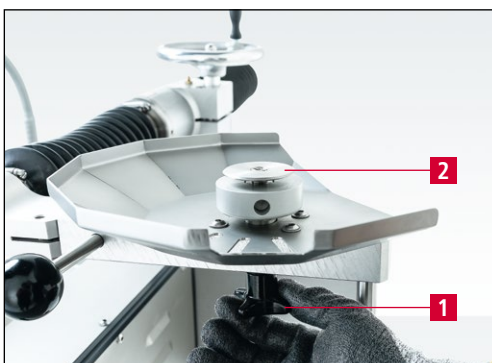

**Figure 7-2** Loosening the locking bolt

Loosen the locking bolt (7-2/1).

Swivel the circular knife grinding attachment backwards.

### 7.1.1 Clamping the circular knife



**Figure 7-3** Remove knife holding fixture

Loosen the star handle (7-3/1) and remove the knife holding fixture (7-3/2) upwards.

# 7. Operation

---



**Figure 7-4** Place circular knife on the appropriate knife holding fixture

Place the circular knife (7-4/1) on the suitable knife holding fixture (7-4/2).



**Figure 7-5** Mounting the circular knife

Insert the knife holding fixture (7-5/1) with the circular knife into the circular knife grinding attachment (7-5/2), hold it firmly and clamp it with the star handle (7-5/3).



**Figure 7-6** Clamping the circular knives

To do this, hold the knife holding fixture with the locking pin (7-6/1) and tighten the star handle (7-6/2).

# 7. Operation

## 7.1.2 Positioning the circular knife on the grinding wheel



**Figure 7-7** Positioning circular knives on the grinding wheel

Swivel the grinding arm with the clamped circular knife forwards onto the grinding wheel.

The cutting edge of the circular knife (7-7/1) must be approximately 15 mm in front of the center of the grinding wheel.

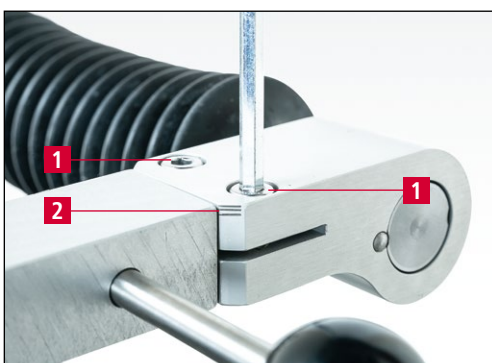

**Figure 7-8** Positioning the circular knife on the grinding wheel

To do this, loosen the lower clamping lever (7-8/1) counterclockwise and move the entire grinding attachment (7-8/2) until the cutting edge of the circular knife is approx. 15 mm in front of the center of the grinding wheel (see figure 7-7).

Retighten the lower clamping lever (7-8/1).

## 7.1.3 Swiveling the circular knife grinding attachment



**Figure 7-9** Swiveling the circular knife grinding attachment

Loosen the two terminal screws (7-9/1) on the mounting head **counterclockwise** with an AF6 mm hexagon screwdriver.

Swivel the mounting arm clockwise until its edge lies on the center marking (7-9/2) of the mounting head.

# 7. Operation

---

## 7.1.4 Setting the grinding angle



**Figure 7-10** Loosening the clamping lever

Place the knife on the grinding wheel to adjust the grinding angle.

Loosen the upper clamping lever (7-10/1) **counterclockwise**.

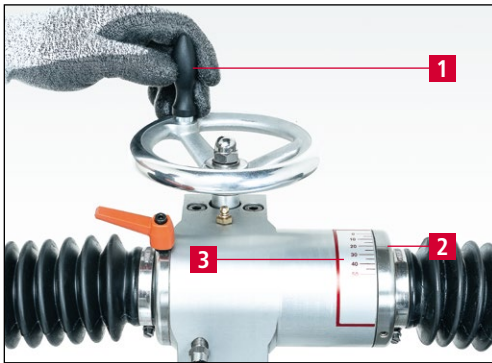

**Figure 7-11** Setting the grinding angle

Turn the hand wheel (7-11/1) until the indicator (7-11/2) shows the desired angle on the angle scale (7-11/3).

Retighten the upper clamping lever (7-10/1).

# 7. Operation

## 7.1.5 Grinding the circular knife



Grinding creates abrasive particles that can enter the eyes.

Wear safety glasses.



Switch on grinding motor (7-12/1) and coolant unit (7-12/2).

Figure 7-12 Switching on the grinding motor and coolant unit

### ATTENTION

The circular knife must rotate counterclockwise. Note the direction of rotation arrow on the knife guard.

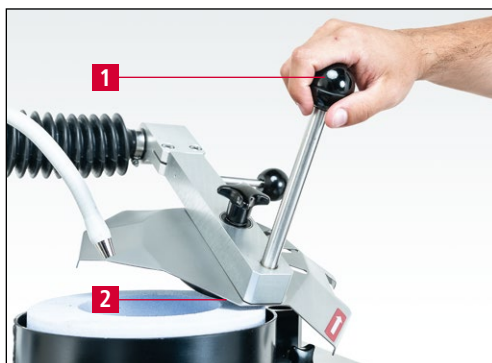

Press the circular knife with the grinding lever (7-13/1) onto the grinding wheel with moderate force. The knife rotates slowly counterclockwise.

Grind until a small burr appears on the cutting edge (7-13/2).

Figure 7-13 Grinding the circular knives

# 7. Operation

---

## 7.1.6 Deburring the circular knife



Deburring creates abrasive particles that can enter the eyes.

Wear safety glasses.



Figure 7-14 Deburring circular knives

Reduce the grinding pressure almost completely.

Hold the silicon carbide dressing stone (7-14/1) flat against the rotating circular knife.

Under water cooling, the burr is removed in a few knife revolutions.

# 7. Operation

---

## 7.2 Grinding circular knives d. 250–470 mm on the grinding wheel

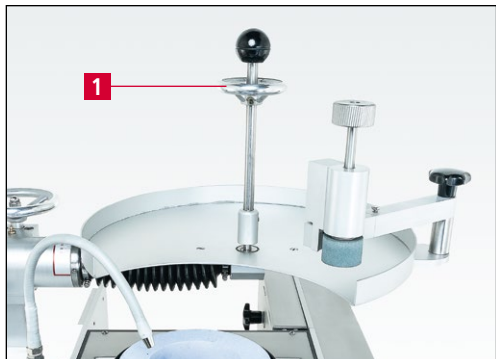

**Figure 7-15** HV25-2 Circular Knife Grinding Attachment

Mount the HV25-2 Circular Knife Grinding Attachment according to the instructions (see Chapter 6.1).

Unscrew the SH 104 grinding lever (7-15/1) **counterclockwise**.

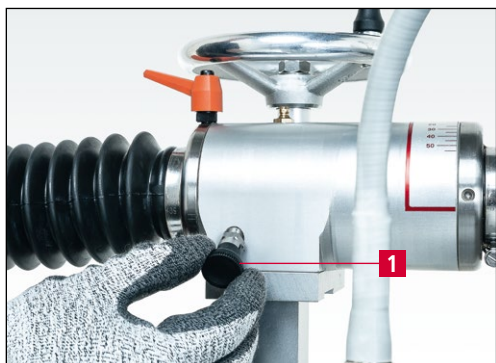
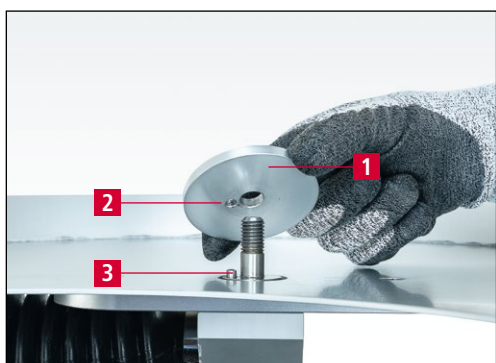

**Figure 7-16** Engaging the locking bolt

Engage the locking bolt (7-16/1).

The grinding arm is now locked against swiveling.

### 7.2.1 Clamping the circular knife

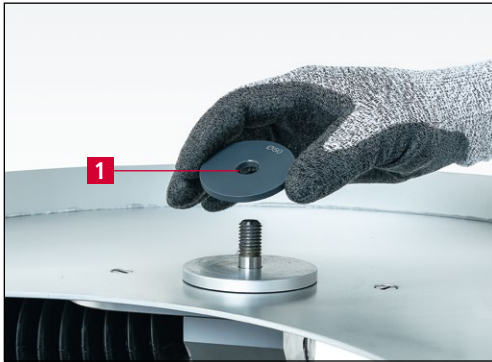

**Figure 7-17** Holding flange d. 70 mm

Place the 70 mm holding flange (7-17/1) onto the locating bolt (7-17/3) with the driving bore (7-17/2) facing downwards.

# 7. Operation

---



**Figure 7-18** Placing the centering disk on the locating bolt

Place the centering disk (7-18/1) corresponding to the knife bore on the locating bolt.

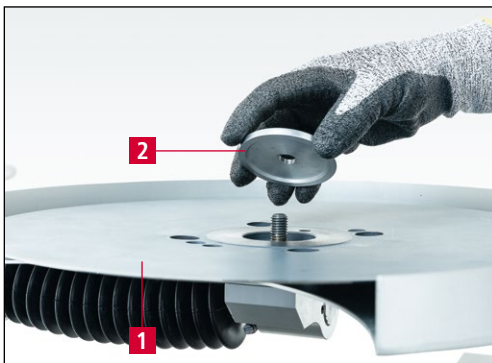

**Figure 7-19** Placing circular knives

Place the circular knife (7-19/1).

Place the 70 mm clamping flange (7-19/2) onto the circular knife.



**Figure 7-20** Clamping circular knives

Clamp the knife with the SH 104 grinding lever (7-20/1).

# 7. Operation

---

## 7.2.2 Positioning the circular knife on the grinding wheel



**Figure 7-21** Positioning circular knives on the grinding wheel

Loosen the locking bolt (7-16/1).

Swivel the grinding arm with the clamped circular knife forward onto the grinding wheel.

The cutting edge of the circular knife (7-21/1) must be approximately 15 mm in front of the grinding wheel center.



**Figure 7-22** Adjusting the circular knife grinding attachment

To do this, loosen the lower clamping lever (7-22/1) counterclockwise and move the complete grinding unit (7-22/2) until the cutting edge of the circular knife is approx. 15 mm in front of the center of the grinding wheel (see figure 7-21).

Retighten the lower clamping lever (7-22/1).

## 7.2.3 Setting the grinding angle



**Figure 7-23** Loosening the clamping lever

To adjust the grinding angle, place the knife on the grinding wheel.

Loosen the upper clamping lever (7-23/1) counterclockwise.

## 7. Operation

---

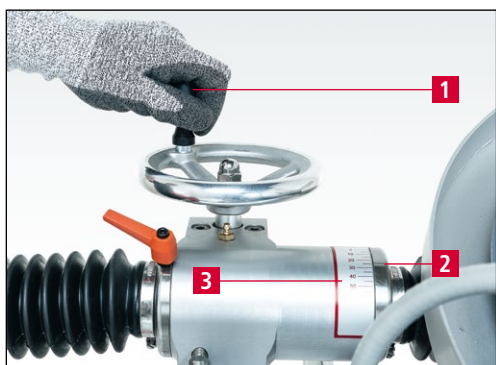

**Figure 7-24** Setting the grinding angle

Turn the hand wheel (7-24/1) until the indicator (7-24/2) shows the desired angle on the angle scale (7-24/3).

Retighten the upper clamping lever (7-23/1).

# 7. Operation

## 7.2.4 Grinding the circular knife



Grinding creates abrasive particles that can enter the eyes.

Wear safety glasses.

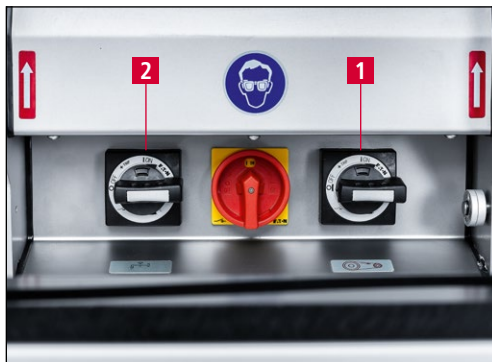

Switch on grinding motor (7-25/1) and coolant unit (7-25/2).

**Figure 7-25** Switching on the grinding motor and coolant unit

### ATTENTION

The circular knife must rotate counterclockwise. Note the direction of rotation arrow on the knife guard.

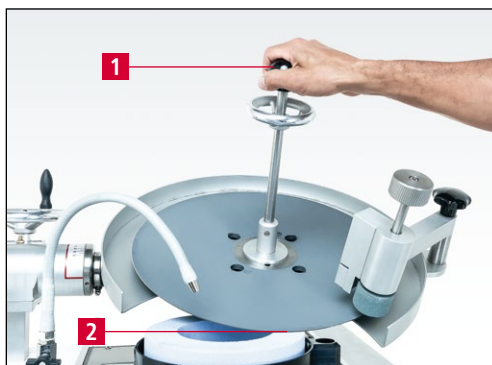

Press the circular knife with the grinding lever (7-26/1) onto the grinding wheel with moderate force. The knife slowly rotates counterclockwise.

Grind until a small burr appears on the cutting edge (7-26/2).

**Figure 7-26** Grinding circular knives

# 7. Operation

## 7.2.5 Deburring the circular knife



Deburring creates abrasive particles that can enter the eyes.

Wear safety glasses.

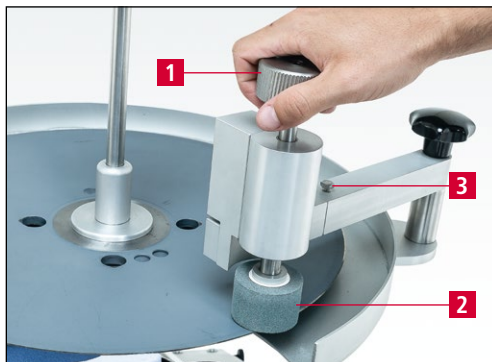

Figure 7-27 Deburring circular knives

Reduce the grinding pressure almost completely.

Swivel the deburring arm (7-27/1) over the cutting edge of the circular knife.

The deburring wheel (7-27/2) should rest approx. 15 mm off-center on the cutting edge of the circular knife.

The deburring wheel rotates slowly over the rotating circular knife. Under water cooling, the burr is removed in a few knife revolutions.



Figure 7-28 Swiveling the deburring arm

If necessary and after consultation with KNECHT, the deburring disk can be swiveled.

To do this, use an AF 10 mm open-end wrench to loosen the hexagon head screw (7-28/1) **counter-clockwise**.

Swivel the deburring arm to the desired position.

Retighten the hexagon head screw (7-28/1).

## 8. Care and maintenance

---



For all work on the grinding machine, observe the locally applicable safety and accident prevention regulations as well as instructions in the "Safety" and "Important notes" section of the operating instructions.

### 8.1 Cleaning

The circular knife grinding attachment must be cleaned after each grinding operation, otherwise the grinding abrasion dries and is difficult to remove.

After cleaning we recommend the products listed below for care of the machine (see also the table of cleaning agents and lubricants in Chapter 8.1.1).

#### 8.1.1 Cleaning agent and lubricant table

Cleaning / Lubrication work	Interflon	Würth	SHELL	EXXON Mobil
Cleaning and care of machine parts	Dry Clean Stainless Steel	Stainless steel care spray	Risella 917	Marcol 82
Lubricate threads and sliding surfaces	Fin Grease	Multi-purpose grease	Gadus S2 V100 2	Ronex MP

### 8.2 Maintenance plan (one-shift operation)

Interval	Assembly	Maintenance task
Daily	All machine surfaces	Clean with soft cloth and care spray.
Weekly	Star handle threads	Lubricate with multi-purpose grease.
	Guideways	Clean and lubricate with multi-purpose grease.
Annually		Contact the service department of KNECHT Maschinenbau GmbH.

# 9. Disassembly and disposal

---

## 9.1 Disassembly

All operating materials must be disposed of properly.

Secure moving parts against slippage.

Disassembly must be conducted by a qualified specialist.

## 9.2 Disposal

After the machine has reached the end of its service life, it must be disposed of by a qualified specialist. In exceptional situations, and after consultation with KNECHT Maschinenbau GmbH, the machine may be returned.

Operating materials (e.g. grinding wheels, grinding belts, finned brushes, etc.) must be disposed of correctly.

# 10. Service, spare parts and accessories

---

## 10.1 Postal address

KNECHT Maschinenbau GmbH  
Witschwender Straße 26  
88368 Bergatreute  
Germany

Phone +49-7527-928-0  
Fax +49-7527-928-32

mail@knecht.eu  
www.knecht.eu

## 10.2 Service

**Service line:**

For address, see postal address

service@knecht.eu

## 10.3 Wear and spare parts

If you need spare parts, please use the spare parts list provided with the machine. Please place your order using the format described below.

**When ordering, please always provide: (example)**

Machine-Type	(HV 25-2)
Designation of assembly	(locating bolt)
Item number (position number)	(10)
Drawing number (article number)	(2000075-2421)
Quantity	(1 pc.)

We are always happy to answer any questions.

# 10. Service, spare parts and accessories

---

## 10.4 Accessories

### 10.4.1 Abrasives used, etc.

Designation	Dimensions	Article Number	Note
Cup wheel (deburring wheel)	d. 50x32x13/40x24 K 120 Si	412B-27-0000	Included in delivery
Silicon carbide dressing stone with handle	35/25x16x225 mm	412P-01-0499	Included in delivery

### ATTENTION

**Only original abrasives, wear and spare parts from KNECHT Maschinenbau GmbH are permitted to be used.**

**KNECHT Maschinenbau GmbH assumes no responsibility for the use of non-original parts.**

If you require abrasives or other accessories, please contact our sales staff and distributors, or KNECHT Maschinenbau GmbH directly.

Thank you for choosing KNECHT!

# 11. Appendix

---

## 11.1 EU Declaration of Conformity

in accordance with EU Directive 2006/42/EU

- Machinery Directive 2006/42/EU
- Electromagnetic Compatibility Directive 2014/30/EU

We hereby declare that the machine designated as follows, due to its construction and design, as well as the version we introduced on the market, complies with the relevant basic safety and health requirements of the applicable EU Directive.

In case of a modification of the machine not agreed with us, this declaration loses its validity.

<b>Designation of machine:</b>	Circular Knife Grinding Attachment
<b>Type designation:</b>	HV 25-1   HV 25-2
<b>Applicable conforming standards, in particular:</b>	DIN EN 12100-1 DIN EN 12100-2 DIN EN 60204-1 ISO 13857 DIN EN 13854
<b>Responsible for documentation:</b>	Andreas Doerr (State-certified technician) Phone +49-7527-928-81 a.doerr@knecht.eu
<b>Manufacturer:</b>	KNECHT Maschinenbau GmbH Witschwender Straße 26 88368 Bergatreute Germany

Technical documentation is available and complete. The operating instructions document for the machine is available in its original version and in the native language of the user.

The validity of the declaration expires in the event of changes to the legal requirements.

Bergatreute, May 26, 2026

KNECHT Maschinenbau GmbH

  
Markus Knecht  
Managing Director

**KNECHT Maschinenbau GmbH**

Witschwender Straße 26 · 88368 Bergatreute · Germany · T +49-7527-928-0 · F +49-7527-928-32  
mail@knecht.eu · www.knecht.eu